

YAGI QWL 5 elementi per i 2m by I3RKE

Forward Gain: 11,22 dBi @ 144,300 MHz
 Front/Back Ratio: 15,87 dB @ 144,300 MHz
 Peak Gain: 11,22 dBi
 Peak F/B: 15,87 dB
 VSWR: inferiore a 1,4:1 da 144,000 MHz a 144,800 MHz

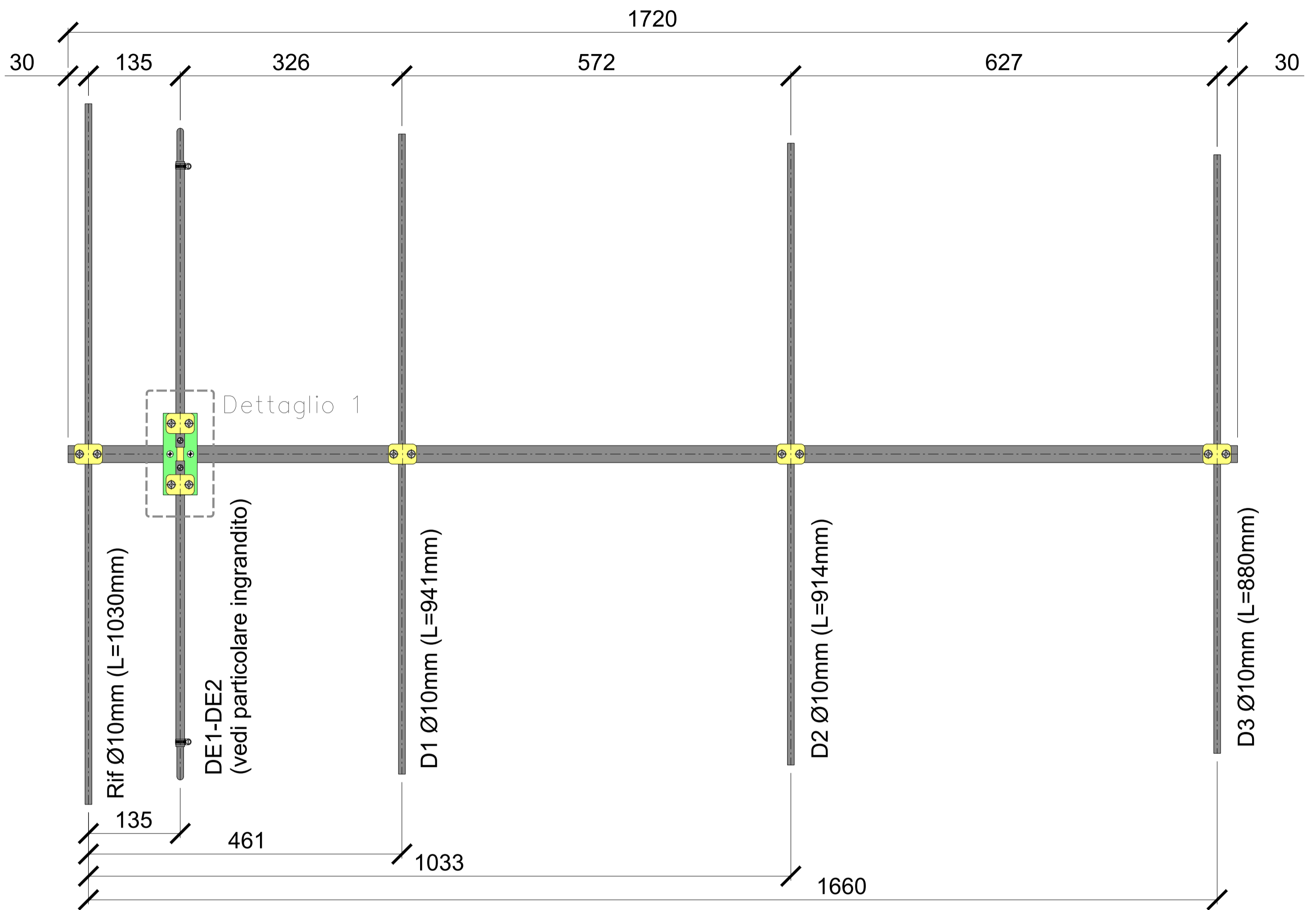

Particolare del dipolo ripiegato

~ 958 (da regolare per il miglior SWR)

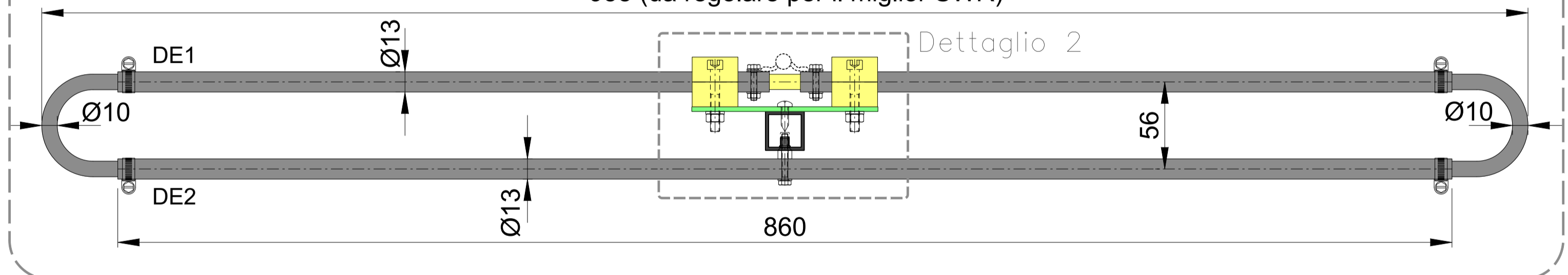

Dettaglio 1

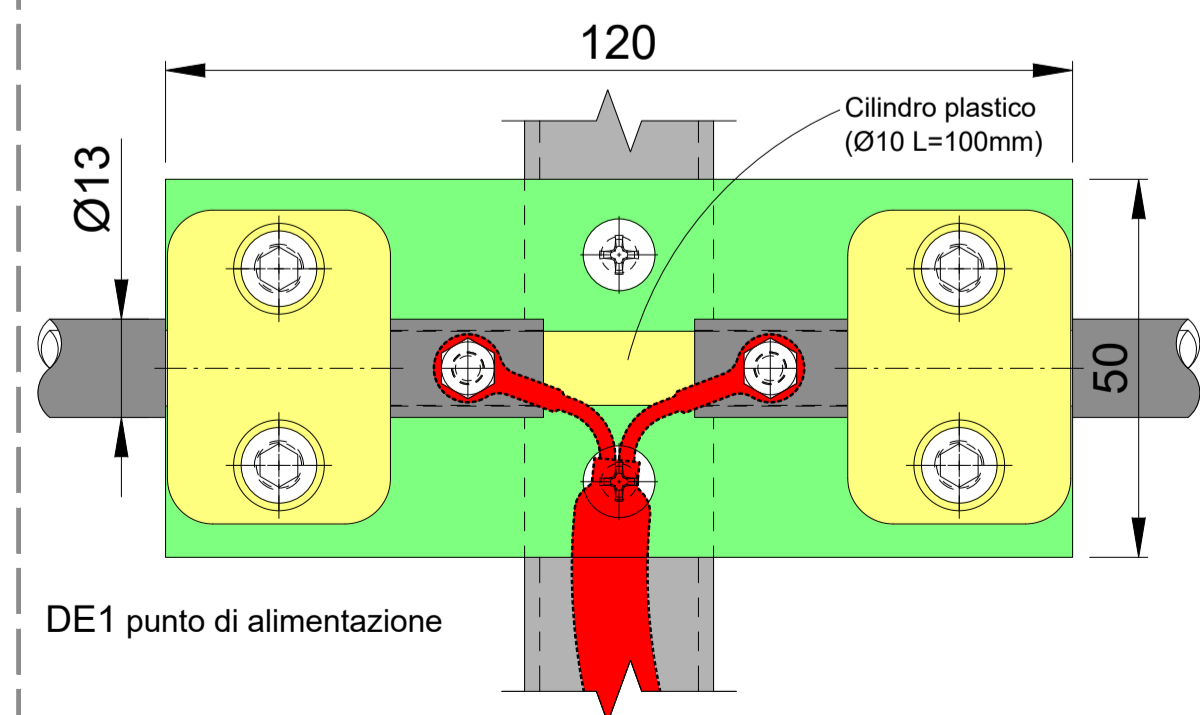

Dettaglio 2

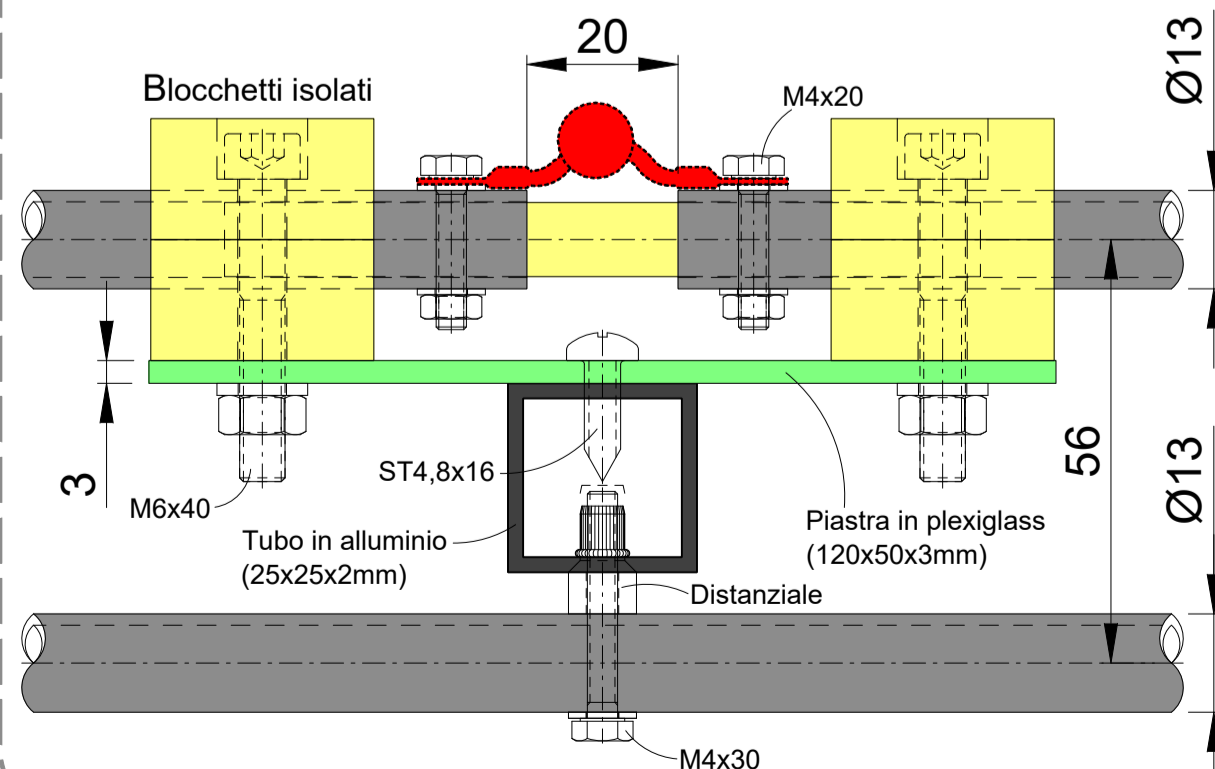

Fissaggio Rif, D1, D2 e D3

